



Product
Data Sheet

Model AF-76

AutoFlagger™

Features

- ◆ Safe operation of 2 signs remotely by a single operator.
- ◆ Smart technology prevents both signs from reading 'SLOW' simultaneously.
- ◆ Large, high visibility signs and overall mast height alert motorists that flagging is in effect.
- ◆ Visual feedback from both the handheld transceiver and side/top strobe lights.
- ◆ Octagonal silhouette and easy, one person set up.
- ◆ 1 mile plus RF range.
- ◆ Rugged, weatherproof design.
- ◆ 3 year warranty.

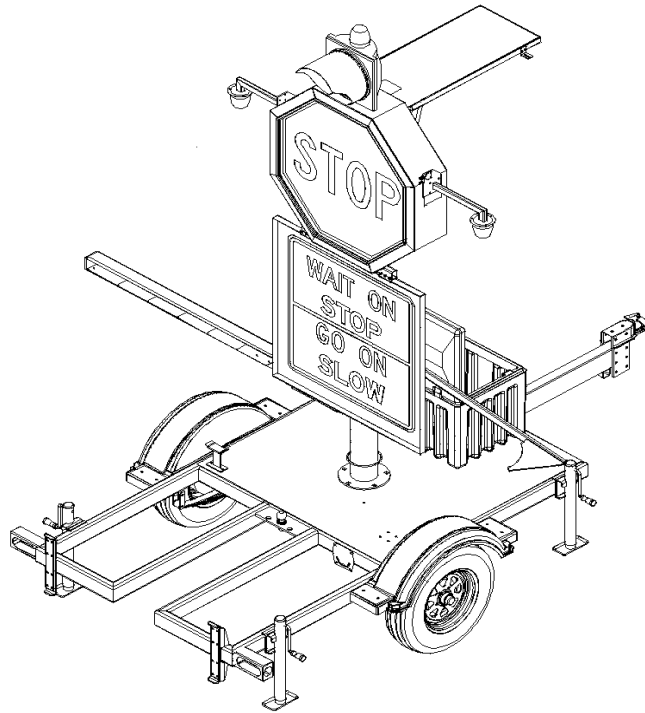

Description

*Shown with optional
Gate arm

The AutoFlagger™ has been field tested for 8 years by MnDOT. This simple to operate, rugged system increases flagger safety by allowing a single person to remotely operate 2 signs from a convenient vantage point, between both signs. Flashing side amber and top red strobes give positive feedback to the operator about each sign position.

An easy to use, wireless, handheld remote controls the signs and also displays the status of each sign. The remote handheld and each sign contain RF transceivers so that each command sent to the sign is continuously monitored and position is verified. A microprocessor in the handheld assures that it is not possible to allow both signs to display 'SLOW' simultaneously.

Worker safety is enhanced since the operator can be moved to the center of the work zone. This gives the operator a clear view of all aspects of the work zone. The operator can observe the flow of vehicles at both ends of the zone, monitor the crew members positions, and adjust the flow of traffic to allow for the entry and exit of DOT equipment. An emergency horn on each sign can be activated by the operator to alert workers of potential danger.

Each sign conforms to the mandatory octagonal silhouette, while maintaining a slim profile for easy transport. The sign heads are fully enclosed and protected against the weather, dust and dirt. Auxiliary lighting, 36" decals, and a large, physical presence help motorists easily recognize that a flagging operation is in effect.

To comply with existing mandates, the signs must be in visual proximity to the operator.

Safety Technologies
28932 Highway 58 Blvd.
Red Wing, MN 55066

For more information call us at:
888-FLAGGER (888-352-4437)
or visit our website at:
www.autoflagger.com



Specifications

General

Overall Length: 147"
Overall Width: 76"
Weight: 1,250 pounds
Operating Height: 143"
Transport Height: 125"
Shipping Height: 107" (Signal head removed)
Tire Size: ST205/75-14C
Paint: Safety Orange
Medium Flat Black
Sign Head Lift: 12vdc Linear Actuator
U.S. Patent #: 5,493,292

Trailer

11ga.x4"x2" Tubular Main Frame, Mitered Corners
11ga.x4"x2" Tubular Cross Members
11ga.x5"x2-1/2" Hitch
3500# Axle
Optional, 10" Electric or Hydraulic Brakes
5/16" Plated, Safety Chains w/ Spring Latch Hooks
1/8" Diamond Plate Deck
4 - Swivel Screw Jacks located on each corner
Peripheral Conspicuity Tape DOT-C2
1/4"x2" Polyethylene Bumper Pads
2" Ball for Second Trailer Coupling
Nested Trailer Design
Polyethylene Fenders
11ga. Tail light housing:
Sealed Beam Tail lights
Main Column is 3/16" wall, 5-1/2" O.D., DOM Tube

Battery/Toolbox

Polyethylene Construction
Keylock w/ Secondary Pad Lock
1- Dual Bay charger for Handheld Battery Packs

Sign Head Assembly

18ga. Hinged Cover
3M, DG Cubed, Regulatory Sign w/ 5" D/E Fonts
18ga. Octagonal Enclosure
3/16" Polycarbonate Front Panel
36", 3M, DG Cubed, 'STOP' Decal
36", 3M, DG Cubed, Florescent Orange 'SLOW'
Decal
12", Red, LED Signal Head w/ Visor
1 - Xenon, Top Red Strobe
2 - Xenon, Side Amber Strobes
RF Controlled, 125db, warning horn
Main Stem is 3/16" wall, 5" O.D., DOM Tube

Wireless/Electrical

Solar Charger

40 Watt, Hinge Mount w/ Gas Shock Absorbers

Handheld Transceiver

LCD Display w/ Backlight
3 - NiMH, Rechargeable Battery Packs
900MHz, Spread Spectrum Transceivers
Range: 1 mile + from operator to sign

Trailer

2 - 31DC Deep Cycle Marine Batteries
Phillips Duraflex Trailer Wiring
7 pole Trailer Plug, or, as per request

Warranty/Shipping

3 years: Repair/Replacement on Defective
Materials and Workmanship
Year 1: on site
Years 2-3: Safety Tech Facility or replacements sent
Batteries/Lights: warranty per manufacturer

Shipping

F.O.B. Safety Technologies Facility, MN